

**NJCAT TECHNOLOGY VERIFICATION**

**AquaLux™ Filtration System**

**Advanced Drainage Systems, Inc.**

**May 2026**

## Table of Contents

Table of Contents.....	i
List of Figures .....	ii
List of Tables .....	iii
1. Description of Technology.....	1
2. Laboratory Testing.....	1
2.1. Test Unit.....	2
2.2. Test Setup.....	3
2.3. Test Sediment.....	4
2.4. Sediment Removal Efficiency and Sediment Mass Capacity Testing .....	6
2.5. Scour Testing.....	8
2.6. Laboratory Proficiency Testing.....	8
3. Performance Claims.....	9
4. Supporting Documentation.....	10
5. Testing Results.....	11
5.1. Flow Rate.....	11
5.2. Water Temperature.....	11
5.3. Head.....	12
5.4. Removal Efficiency Testing Results.....	13
5.5. Sediment Mass Capacity Testing Results.....	17
5.6. Sediment Mass Loading.....	22
5.7. Scour Test Results.....	23
6. Design Limitations.....	24
7. Maintenance.....	25
8. Statements.....	26
9. References.....	32
10. Verification Appendix .....	33

## List of Figures

Figure 1: AquaLux™ Filtration System (ALUX-3M) .....	1
Figure 2: Profile View and Plan View of ALUX-3M Test Unit .....	2
Figure 3: Schematic of the ALUX-3M Test Configuration .....	3
Figure 4: ALUX-3M Test Unit Sediment Dosing Port, Background Sampling Point, and Effluent Sampling Point .....	4
Figure 5: Average Particle Size Distribution of Test Sediment .....	5
Figure 6: Removal Efficiency vs. Sediment Mass Loading .....	22
Figure 7: Head vs. Sediment Mass Loading .....	22

## List of Tables

Table 1 Particle Size Distribution Results of Test Sediment Samples .....	5
Table 2: Removal Efficiency and Sediment Mass Capacity Sampling Schedule .....	7
Table 3: FTL Proficiency Testing Results .....	9
Table 4: Flow Rate and Temperature Summary .....	12
Table 5: Maximum Head .....	13
Table 6: Removal Efficiency Testing Effluent, Drawdown and Background TSS .....	14
Table 7: Removal Efficiency Testing Sediment Feed Rate .....	14
Table 8: Removal Efficiency Testing Influent TSS .....	15
Table 9: Removal Efficiency Testing Effluent TSS .....	16
Table 10: Removal Efficiency Testing Drawdown TSS .....	16
Table 11: Summary of Removal Efficiency Results .....	17
Table 12: Sediment Mass Capacity Testing Effluent, Drawdown and Background TSS.....	18
Table 13: Sediment Mass Capacity Testing Sediment Feed Rate .....	19
Table 14: Sediment Mass Capacity Testing Influent TSS .....	19
Table 15: Sediment Mass Capacity Testing Effluent TSS .....	20
Table 16: Sediment Mass Capacity Testing Drawdown TSS .....	21
Table 17: Summary of Sediment Mass Capacity Results .....	21
Table 18: Scour Test Sampling Schedule .....	23
Table 19: Scour Test TSS Results .....	23
Table A-1: AquaLux Model MTFRs and New Jersey Maximum Allowable Drainage Area..	35

## 1. Description of Technology

The ADS AquaLux™ filtration system provides stormwater treatment for urban land uses, primarily targeting runoff from paved surfaces such as parking lots, roadways, and rooftops. The system removes sediment through two primary mechanisms: (1) gravitational settling, and (2) filtration. As shown in **Figure 1**, stormwater runoff enters the ADS AquaLux™ through either a pipe inlet or curb inlet and is conveyed into the influent chamber. This chamber provides pretreatment by capturing coarse sediments, trash, and debris. A baffle wall promotes the separation of floatables and settleable solids by allowing floatables to rise and coarse sediments to settle into the sump before the water flows upward into the filtration chamber. In the filtration chamber, flow passes through an array of membrane filter elements. Fine sediments and particulate-bound pollutants are removed through membrane filtration. Following treatment, water enters the effluent chamber above the deck and discharges through the outlet pipe.

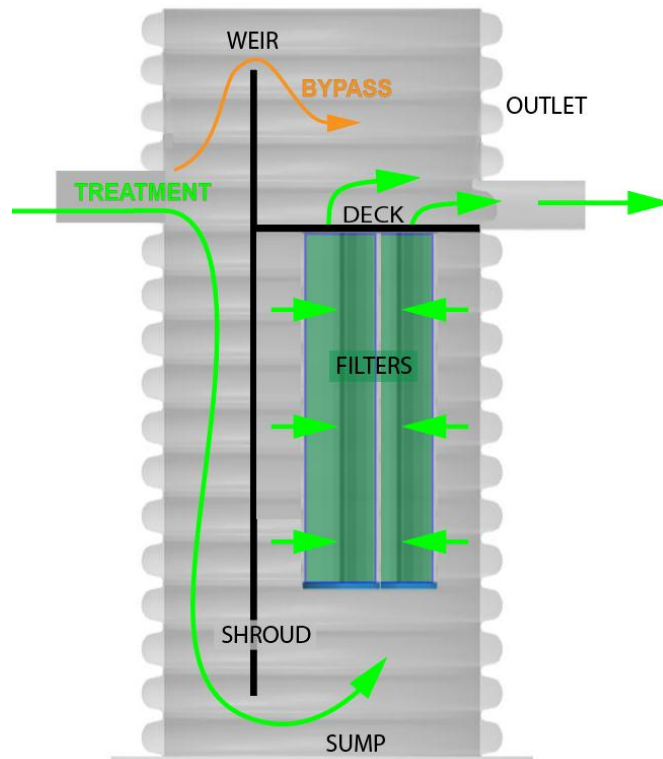

**Figure 1: AquaLux™ Filtration System (ALUX-3M)**

## 2. Laboratory Testing

Beginning in April 2026, an ALUX-3M commercial size unit was installed at the ADS Engineering and Technology Center's Hydraulics laboratory in Hilliard, Ohio to evaluate the performance of the ALUX-3M for Total Suspended Solids (TSS) removal, Sediment Mass Loading Capacity and Scour.

Sustainable Stormwater Solutions Engineering (SSSE) provided third-party review and oversight of all testing and data collection in accordance with the *New Jersey Department of Environmental Protection Laboratory Protocol to Assess Total Suspended Solids Removal by a Filtration Manufactured Treatment Device*, January 14, 2022, Last updated April 25, 2023 (NJDEP Filter Protocol). All sediment concentrations samples collected during the test program were analyzed by an independent, accredited environmental testing laboratory, Fredericktowne Labs (FTL) using ASTM D3977 “Standard Test Methods for Determining Sediment Concentration in Water Samples.” All sediment PSD samples were analyzed by Bowser-Morner, Inc. (BMI) an ISO certified analytical laboratory in accordance with ASTM D6913 and ASTM D7928 methods. The moisture content of the test sediment was determined by BMI in accordance with ASTM Method D2216. The NJDEP approval process requires submittal of a Quality Assurance Project Plan (QAPP) to the New Jersey Corporation for Advanced Technology (NJCAT) for review and approval prior to testing to ensure that all laboratory procedures will be conducted in accordance with the NJDEP Filter Protocol. The QAPP was submitted and approved by NJCAT in March of 2026, prior to commencement of testing.

## 2.1. Test Unit

The test unit was a full-scale commercially available ALUX-3M unit (23.5 inch diameter), shown in **Figure 2**. Influent and effluent piping to the ALUX-3M unit was 4-inch in diameter. The inlet pipe slope was greater than 1%. The tested unit consists of three AquaLux™ filters housed in a plastic manhole structure. Per the test plan approved by NJCAT, a false floor was set to simulate 50% of the maximum sediment storage volume for the removal efficiency testing and sediment mass capacity testing. The test unit dimensions were confirmed by SSSE prior to testing.

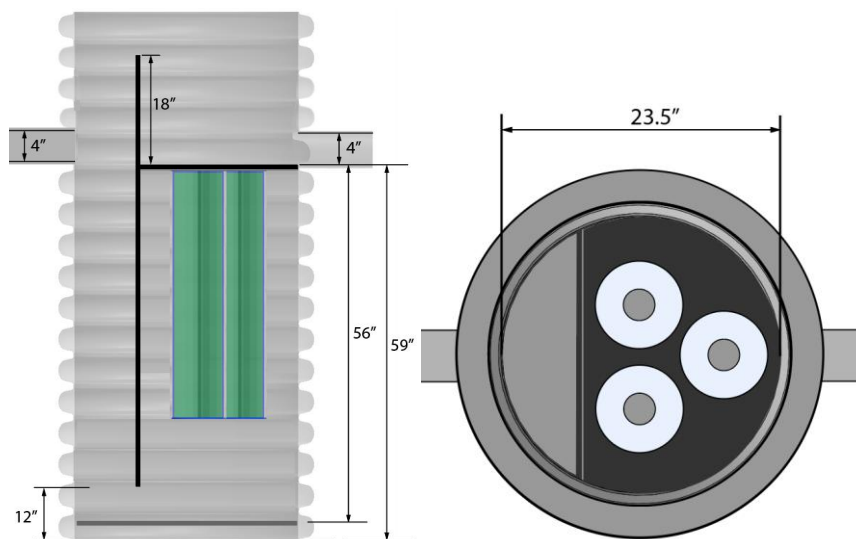

**Figure 2: Profile View and Plan View of ALUX-3M Test Unit**

## 2.2. Test Setup

A schematic of the closed-loop recirculating test configuration is shown in **Figure 3**. Flow rate was controlled using a Bell & Gossett e-1510 5EB pump and an Emerson Keystone 22L0250 control valve. The Variable Frequency Drive (VFD) control system automatically adjusted the pump speed and control valve position to achieve the desired flow rate from the source tank. The flow rates were measured upstream of the test unit using a 4-inch Emerson Magnetic 8750 flow meter. The water temperature in the source tank was measured using a Rosemount 214A Temperature Sensor. All flow rate and temperature data were recorded in one-minute intervals. Water temperature did not exceed 80 °F at any point during testing.

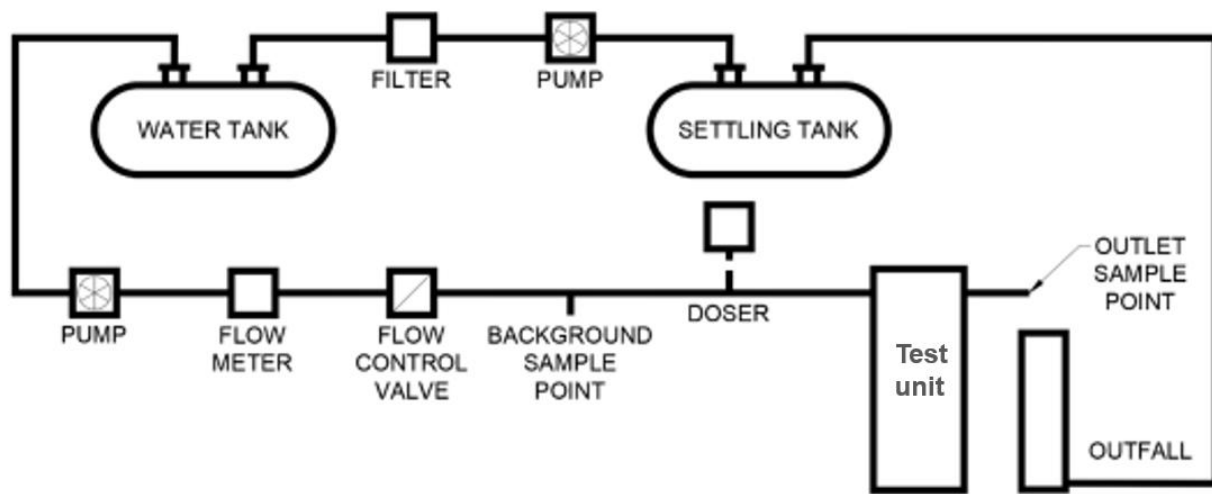

**Figure 3: Schematic of the ALUX-3M Test Configuration**

Test sediment was dry fed by a Coperion K-tron gravimetric screw doser at a distance of 26 inches upstream of the test unit as shown in **Figure 4**. The dosing rate was calculated to deliver an amount of sediment that, when mixed with the water from the source tank, would produce influent water with a target test sediment concentration of 200 mg/L. The water flowed through the inlet chamber and filters of the test unit, and the effluent was discharged into the outfall. The effluent flowed to an underground settling tank, through a pressurized filter bag system, and was returned to the source tank. Background TSS (TSS) sample collection occurred approximately 22 feet upstream of the sediment dosing port in correspondence with the odd numbered effluent samples. The grab-sampling method was used for all TSS sample collection by sweeping a wide-mouth 1-L plastic bottle through the open flowing stream. All TSS samples were at least 500 mL.



**Figure 4: ALUX-3M Test Unit Sediment Dosing Port, Background Sampling Point, and Effluent Sampling Point**

The head reading was recorded at a minimum of five-minute intervals, as well as the start and end of each test run, and when samples were collected. The standpipe head measurement tolerance was  $\pm 1/64$  inch using the engineering scale. Two evenly-volume-spaced drawdown samples were collected at  $1/3$  and  $2/3$  of the drawdown volume after flow stopped at the end of each run. Run times and sampling times were measured using a GANXIN GX-IR05 digital timer.

Three sediment feed samples were collected from the injection point during the test for verification of sediment feed rate, in a clean container over an interval timed to the nearest second, with a minimum volume of 0.1 liter or a collection interval not exceeding one minute (whichever comes first). The samples were weighed to the nearest 0.1g under the observation of SSSE. The duration of each run was 33.5 minutes.

### **2.3. Test Sediment**

The test sediment for removal efficiency, sediment mass loading capacity and scour testing was a blend of commercially available silica sand grades supplied by AGSCO Corporation. The particle size distribution was independently verified by Bowser-Morner, Inc. (BMI) to show that the test sediment blend meets the specification as described in Section 4A of the Protocol.

Sediment containers were affixed with seals under third-party observation and remained sealed until the time of testing. All openings and subsequent use of the sediment were performed under third-party observation. SSSE observed the collection of three representative samples composited from each of the containers prior to the start of testing. Results of particle size gradation testing are shown in **Table 1** and **Figure 5** below. The  $D_{50}$  of this blend was 67.5 microns.

**Table 1 Particle Size Distribution Results of Test Sediment Samples**

Particle Size (um)	% Finer <sup>1</sup>				Test Sediment Average	NJDEP Specification (minimum % passing)
	NJDEP Protocol	Sample 1	Sample 2	Sample 3		
1000	100	99.2	99.1	99.1	99.2	98
500	95	95.0	94.7	94.9	94.9	93
250	90	90.1	89.7	90.1	90.0	88
150	75	80.6	79.2	80.3	80.0	73
100	60	61.3	61.3	61.9	61.5	58
75	50	51.6	52.4	52.7	52.2	50
50	45	48.0	45.4	48.0	47.1	43
20	35	37.0	33.0	36.2	35.4	33
8	20	20.3	17.6	19.8	19.2	18
5	10	14.5	11.4	13.1	13.0	8
2	5	5.9	3.4	4.4	4.6	3
D <sub>50</sub>	<75µm	68.8µm	68.1µm	65.5µm	67.5µm	

<sup>1</sup> Where required, particle size data has been interpolated to allow for comparison to the required NJDEP particle size specification.

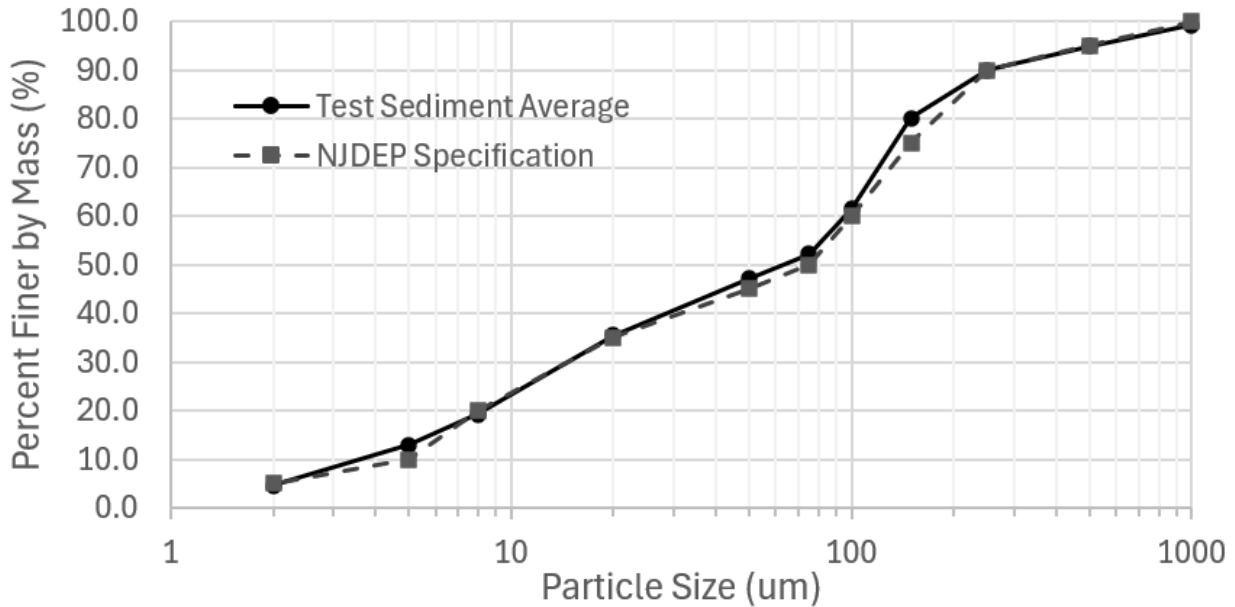

**Figure 5: Average Particle Size Distribution of Test Sediment**

## 2.4. Sediment Removal Efficiency and Sediment Mass Capacity Testing

Sediment removal efficiency and sediment mass capacity testing adhered to the guidelines set forth in Section 4 of the NJDEP Laboratory Protocol for Filtration MTDs. A three-inch false floor was installed prior to testing to stimulate 50% of the maximum sediment storage capacity, in accordance with the approved QAPP. The target flow rate applied to the ALUX-3M test unit during testing was 60 gpm. For each test, testing commenced once the flow rate stabilized at the target value. The flow rate was held steady during the test at  $\pm 10\%$  of the target value with a coefficient of variation (COV) not exceeding 0.03. Test runs continue until the maximum design driving head was reached. Then the influent flow rate was reduced to 90% of the Maximum Treatment Flow Rate (MTFR) and testing resumed until maximum design driving head was reached again, at which time testing was concluded.

The test sediment screw-auger feeder (doser) introduced the test sediment into the feed water stream to achieve the target influent TSS concentration of 200 mg/L. According to the NJDEP Filter Protocol, this influent concentration must stay within 10% of the target. In order to confirm sediment feed rates during the test, in accordance with the NJDEP Filter Protocol, three samples of the test sediment were collected from the injection point into a clean container for verification of sediment feed rate, over an interval time to the nearest second, with a minimum volume of 0.1 liter or a collection interval not exceeding one minute (whichever came first). The time was kept with a stopwatch. The samples were weighed to the nearest milligram under the observation of SSSE. The sediment feed rate coefficient of variance (COV) for the test sediment samples cannot exceed 0.10.

Effluent sampling was performed by grab sampling method during each run, according to the schedule in **Table 2**. When the test sediment feed was interrupted for test sediment rate measurements, the next effluent samples were collected after at least three detention times had elapsed. During the drawdown period, two evenly-volume-spaced effluent samples were collected after the flow was cut off at the end of each run. Three background samples were taken in correspondence with the odd-numbered effluent samples to ensure tank source water met the sediment concentration requirement. According to the NJDEP Filter Protocol, these background concentrations cannot exceed TSS of 20 mg/L.

All TSS samples were collected in 1-L wide mouth bottles. Individual sample volumes were greater than 500 mL. FTL performed analysis of all background, drawdown, and effluent samples under test method ASTM D3977-97 "Standard Test Methods for Determining Sediment Concentrations in Water Samples." A chain of custody (COC) form was used for each test run to record sampling date and time for externally analyzed samples. Copies of these forms were maintained by ADS Hydraulic lab and FTL. SSSE witnessed labeling, completion of COC forms, packaging and application of security seals of samples for shipment to the external laboratory (FTL).

**Table 2: Removal Efficiency and Sediment Mass Capacity Sampling Schedule**

Time (minutes)	Sediment Sample	Effluent Sample	Background Sample
0	S1		
8		E1	BG1
12		E2	
16	S2		
24		E3	BG2
28		E4	
32		E5	BG3
32.5	S3		
1/3 Drawdown		DD1	
2/3 Drawdown		DD2	

Note: S= sediment rate; E=Effluent sample; BG=background; DD=drawdown

The mass of sediment collected from the influent pipe after each run was subtracted from the total mass of test sediment added during dosing to yield the Net mass. Average Influent Concentration is the Net mass divided by the volume of water that flowed through the ALUX-3M test unit during dosing, as follows:

$$\text{Average Influent Concentration} = \frac{\text{Net mass}}{\text{Total volume of water flowing through the MTD during addition of test sediment}}$$

The volume of water flowing through the device during the run was calculated by multiplying the average flow rate by the time of sediment injection only. The mass from the sediment feed rate measurement samples was subtracted from the total mass introduced to the system when removal efficiency was calculated.

Two evenly volume-spaced samples were collected of drawdown effluent to determine the TSS concentration and included in the removal efficiency calculations. Individual run removal efficiency was calculated as follows:

$$\text{Removal Efficiency (\%)} = \frac{\left( \frac{\text{Average Influent TSS Concentration} \times \text{Total Volume of Test Water}}{\text{Total Volume of Test Water}} \right) - \left( \frac{\text{Adjusted Effluent TSS Concentration} \times \text{Total Volume of Effluent Water}}{\text{Total Volume of Effluent Water}} \right) - \left( \frac{\text{Average Drawdown Flow TSS Concentration} \times \text{Total Volume of Drawdown Water}}{\text{Total Volume of Drawdown Water}} \right)}{\text{Average Influent TSS Concentration} \times \text{Total Volume of Test Water}} \times 100$$

## 2.5. Scour Testing

Scour testing was performed to demonstrate that the AquaLux™ Filtration system can be operated on-line. The test was performed at a target flow rate of 125 gpm (208% of the MFTR). In accordance with the NJDEP Filter Protocol, the average effluent concentration during the scour run must be less than 20 mg/L above the background concentration.

Scouring testing was performed on the ALUX-3M unit using mature filters following completion of the removal efficiency and sediment mass capacity testing. The sump was cleaned and loaded with NJDEP blend sediment. NJDEP blend sediment was added to the sump without the false floor in place until three inches of sediment was evenly distributed across the entire sump. The system was then filled with clean water to its normal, dry weather operating depth. Commencement of the scour test started approximately 89 hours after preloading the test unit.

The scour run commenced by conveying clean water through the ALUX-3M at increasing flow rates. The flow rate was increased to the target flow rate (125 gpm) within three minutes of commencement of the test. The flow rate then remained constant at the target flow rate for the remainder of the test duration. The flow rate was recorded once per minute for the duration of the test. Fifteen (15) effluent samples were taken at 1, 3 and 5 minutes after flow commencement and then every two minutes thereafter for an additional 12 samples (i.e., 7, 9, 11....19 minutes). All 15 samples were used to determine the average effluent concentration.

Eight background samples of the clear water to the ALUX-3M were collected at evenly spaced intervals throughout the duration of the scour test. All samples (background and effluent) were analyzed by FTL for TSS in accordance with ASTM D3977 “Standard Test Methods for Determining Sediment Concentrations in Water Samples.” The maximum allowable background concentration in the clear water did not exceed 20 mg/L.

All effluent sample results from the scour test run were adjusted by subtracting the background concentration from the recorded effluent sample concentration.

## 2.6. Laboratory Proficiency Testing

Six spiked TSS samples, three at a concentration around 22 mg/L and three others at concentration of around 50 mg/L were prepared by ADS using the same test sediment as for the removal performance testing overseen by SSSE. These samples were analyzed by FTL for sediment concentration in accordance with ASTM Method D3977-97 “Standard Test Method for Determining Sediment Concentrations in Water Samples.” The results of the Laboratory Proficiency Testing are summarized in **Table 3** below.

**Table 3: FTL Proficiency Testing Results**

Sample ID	Sample Concentration (mg/L)	Reported TSS	% Recovery
Spiked# A1	21.97	20.1	91.5
Spiked# A2	22.21	24.2	108.9
Spiked# A3	22.13	23.5	106.2
		Average	102.2
Spiked# B1	49.50	52.6	106.3
Spiked# B2	50.00	53.2	106.4
Spiked# B3	49.77	53.0	106.5
		Average	106.4

The average recovery percentage of the spiked TSS samples was 102.2% at ~22 mg/L and 106.4% at ~50 mg/L, meeting the protocol requirement of 85-115%. Thus, FTL passed the Laboratory Proficiency Testing for TSS analysis.

### 3. Performance Claims

Per the NJDEP verification procedure and based on the laboratory testing conducted for the ALUX-3M System, the following are the performance claims made by Advanced Drainage Systems, Inc.

#### *Total Suspended Solids (TSS) Removal Efficiency*

Based on the testing conducted, the AquaLux™ system achieved a cumulative TSS removal efficiency of 91.1% after ten qualifying runs, calculated in accordance with the NJDEP Protocol. In accordance with Section 5.C of the *Procedure for Obtaining Verification of a Stormwater Manufactured Treatment Device from the New Jersey Corporation for Advanced Technology* (dated August 4, 2021), this value was rounded down to 80%.

#### *Maximum Treatment Flow Rate (MTFR)*

The ALUX-3M demonstrated an MTFR of 0.134 cfs (60 gpm). This corresponds to a Surface Loading Rate (SLR) of 0.146 gpm/ft<sup>2</sup> of EFTA.

### *Detention Time and Volume*

The maximum operational wet volume (WV) of 15.9 ft<sup>3</sup> for an ALUX-3M test unit produces a detention time of 1.98 minutes at 60 gpm. The associated water level for this maximum operational wet volume was 18 inches above the deck, the height of the bypass wall.

### *Effective Sedimentation Treatment Area*

The Effective Sedimentation Treatment Area (ESTA) increases as the size of the ALUX-3M increases, with a large-scale system having a higher ESTA. Under test conditions with an ALUX-3M, the ESTA is 3.01 ft<sup>2</sup>.

### *Effective Filtration Treatment Area*

The Effective Filtration Treatment Area (EFTA) increases as the size of the ALUX-3M increases, with a large-scale system having a higher EFTA. Under test conditions with an ALUX-3M, the EFTA is 411 ft<sup>2</sup>. The ratio ESTA/EFTA was 0.0073.

### *Sediment Load Capacity*

The ALUX-3M unit tested received a mass load of 63.4 lbs of sediment over the 21 runs, with a mass load that was captured of 57.4 lbs. This equates to 0.14 lbs/ft<sup>2</sup> of EFTA.

### *Maximum Allowable Inflow Drainage Area*

Laboratory testing results showed that 63.4 lbs of sediment can be loaded into an ALUX-3M. Per the NJDEP Filter Protocol, to calculate the maximum inflow drainage area, the total sediment load captured during the test (57.4 lbs) is divided by 600 lb/acre. Thus, the maximum inflow drainage area is 0.096 acres for ALUX-3M.

## **4. Supporting Documentation**

To support the performance claims, NJCAT was provided with copies of the laboratory test reports, all collected and measured data, spreadsheets containing original data from all performance test runs, all pertinent calculations, and related supporting materials for review. NJDEP agreed that, as long as this documentation is available upon request, inclusion of all such documentation within this verification report was not necessary. All supporting documentation has been submitted to NJCAT and is available upon request.

## 5. Testing Results

A total of 10 removal efficiency testing runs, and 11 mass capacity runs were completed in accordance with the NJDEP filter protocol. The target influent sediment concentrations for removal efficiency runs and mass capacity runs were 200 mg/L. The results from all removal efficiency runs were used to calculate an overall cumulative removal efficiency of the ALUX-3M at the design flow rate of 60 gpm. Run 18 was disqualified from the removal efficiency evaluation because its feed rate exceeded a COV of 0.10. However, the sediment introduced during this run is still incorporated into the calculation of the total sediment mass load capacity.

### 5.1. Flow Rate

Flow rate was recorded by an Emerson Magnetic 8750 flow meter every minute during each run. For each run, the flow rate was maintained within 10% of the target flow rate (54.0 – 66.0 gpm at 100% MTRF, and 48.6 – 59.4gpm at 90% MTRF). As shown in **Table 4**, the associated COV was also within compliance of the NJDEP protocol for all runs.

### 5.2. Water Temperature

The water temperature in the source tank was measured using a Rosemount 214A Temperature Sensor. The average water temperature for all runs was 58.59 degrees Fahrenheit, with a maximum of 64.65 degrees Fahrenheit, meeting the NJDEP Filter Protocol requirement to be below 80 degrees Fahrenheit. Data is summarized in **Table 4**.

**Table 4: Flow Rate and Temperature Summary**

<b>Run #</b>	<b>Max Flow (gpm)</b>	<b>Min Flow (gpm)</b>	<b>Average Flow (gpm)</b>	<b>Flow COV</b>	<b>Flow Compliance (COV ≤ 0.03)</b>	<b>Maximum Temperature (Fahrenheit)</b>	<b>NJDEP Temperature Compliance (≤ 80 F)</b>
1	61.70	57.38	59.98	0.018	Y	63.63	Y
2	62.44	57.56	60.13	0.016	Y	58.99	Y
3	61.74	58.05	60.08	0.014	Y	64.65	Y
4	63.16	56.43	59.98	0.021	Y	58.99	Y
5	62.81	57.04	60.02	0.027	Y	58.99	Y
6	63.20	58.00	60.12	0.017	Y	63.80	Y
7	63.36	56.66	60.06	0.027	Y	57.96	Y
8	62.16	57.22	59.99	0.021	Y	57.96	Y
9	63.47	57.49	60.11	0.027	Y	62.08	Y
10	63.12	57.86	60.03	0.016	Y	58.82	Y
11	63.01	57.00	60.07	0.023	Y	58.13	Y
12	62.31	57.44	60.02	0.023	Y	60.88	Y
13	62.55	57.05	60.08	0.026	Y	58.99	Y
14	63.12	56.40	60.08	0.027	Y	61.40	Y
15	61.79	56.72	59.96	0.020	Y	58.99	Y
16	64.97	57.44	60.11	0.023	Y	60.02	Y
17	63.51	57.56	60.10	0.015	Y	64.31	Y
18	62.66	57.36	59.96	0.017	Y	58.48	Y
19	61.08	56.85	60.12	0.015	Y	58.65	Y
20	64.96	57.82	61.15	0.019	Y	62.08	Y
21	55.74	50.89	54.00	0.017	Y	58.48	Y

### 5.3. Head

Maximum head, measured from the outlet pipe invert (datum 0 inches) in the inlet chamber, is shown in **Table 5**. When the maximum head exceeded 18 inches, the MTFR was reduced to 90% of MTFR. Testing continued at the reduced flow rate until the maximum head was again reached, marking the conclusion of testing. The highest head observed during the testing was 18.375 inches.

**Table 5: Maximum Head**

<b>Run #</b>	<b>Average Flow (gpm)</b>	<b>Maximum Inlet Chamber head (inches)</b>	<b>Maximum Outlet Chamber head (inches)</b>
1	59.98	4.750	3.750
2	60.13	5.500	3.750
3	60.08	5.000	3.875
4	59.98	5.500	4.000
5	60.02	6.375	3.750
6	60.12	5.750	3.750
7	60.06	7.375	3.750
8	59.99	8.125	3.750
9	60.11	8.250	3.750
10	60.03	9.625	3.750
11	60.07	10.500	4.000
12	60.02	11.500	3.875
13	60.08	12.875	3.875
14	60.08	13.750	3.750
15	59.96	15.125	4.000
16	60.11	15.750	4.000
17	60.10	15.875	4.000
18	59.96	16.500	4.000
19	60.12	17.375	3.875
20	61.15	18.375	3.750
21	54.00	18.250	3.625

#### **5.4. Removal Efficiency Testing Results**

##### *Background TSS*

The background, effluent and drawdown TSS concentrations for each run are provided in **Table 6**. The NJDEP Protocol specifies a maximum allowable background concentration of 20.0 mg/L for individual samples, and all measured values were below this limit. In accordance with the protocol, the background TSS concentration for each run was subtracted from the effluent to obtain adjusted values. For samples in which the background TSS was reported as less than the method quantitation limit of 1.0 mg/L, a concentration of 0.5 mg/L was applied for the purpose of calculating adjusted effluent concentrations.

**Table 6: Removal Efficiency Testing Effluent, Drawdown and Background TSS**

Run #	Effluent 1 (mg/L)	Effluent 2 (mg/L)	Effluent 3 (mg/L)	Effluent 4 (mg/L)	Effluent 5 (mg/L)	Draw-down 1 (mg/L)	Draw-down 2 (mg/L)	Back-ground 1 (mg/L)	Back-ground 2 (mg/L)	Back-ground 3 (mg/L)	NJDEP Background Compliance ( $\leq 20$ mg/L)
1	18.1	16.7	17.8	16.4	15.5	17.7	19.7	0.5	0.5	0.5	Y
2	17.7	18.3	18.4	17.2	17.9	18.2	18.0	0.5	0.5	0.5	Y
3	15.7	18.9	19.2	17.3	16.2	16.6	17.0	1.2	1.7	0.5	Y
4	15.2	20.6	15.9	19.3	17.0	20.8	18.3	0.5	1.3	1.3	Y
5	16.4	20.0	17.7	18.3	19.2	20.7	20.1	1.3	1.3	1.8	Y
6	18.0	21.6	16.9	20.7	19.1	23.4	19.1	1.4	1.2	1.2	Y
7	17.3	16.7	19.9	20.2	19.3	24.5	23.8	1.2	1.1	1.3	Y
8	19.6	21.7	22.4	20.9	20.7	23.9	24.2	1.5	1.3	1.4	Y
9	23.7	29.5	22.9	21.9	27.6	21.2	23.6	4.3	3.0	3.7	Y
10	19.1	23.6	23.4	22.3	22.4	27.5	27.4	4.0	4.2	4.1	Y

*Sediment Dosing Rate and Influent TSS*

**Table 7** provides the measured sediment feed rates for each run. In this table, NJDEP Protocol compliance is defined as a COV  $\leq 0.1$ .

**Table 7: Removal Efficiency Testing Sediment Feed Rate**

Run #	Moisture Corrected Feed Rate			Average Feed Rate	Sediment Feed Rate COV	NJDEP COV Compliance ( $\leq 0.1$ )
	(g/min)			(g/min)		
1	46.344	44.959	46.264	45.855	0.017	Y
2	48.029	47.247	44.456	46.578	0.040	Y
3	49.695	46.760	45.134	47.196	0.049	Y
4	44.075	47.869	47.359	46.434	0.044	Y
5	48.622	48.831	44.326	47.260	0.054	Y
6	48.280	45.598	48.230	47.369	0.032	Y
7	45.261	43.586	46.582	45.143	0.033	Y
8	46.915	46.564	47.420	46.966	0.009	Y
9	47.382	45.571	46.371	46.441	0.020	Y
10	45.712	46.664	45.675	46.017	0.012	Y

Influent TSS concentrations as shown in **Table 8** were calculated by dividing the total mass of sediment added to the test unit (minus the mass retained in the inlet pipe) during a given run by the total volume of water flowing through the AquaLux™ test unit during the addition of test sediment during that run. The volume of water flowing through the device during the run was calculated by multiplying the average flow rate by the time of sediment injected only.

**Table 8: Removal Efficiency Testing Influent TSS**

Run #	Average Flow Rate	Total Water Volume	Dosed Sediment Mass	Feed Rate Samples Mass	Sediment Recovered from Inlet	Net Mass	Influent TSS	NJDEP Compliance (180 - 220 mg/L)
	(gpm)	(L)	(g)	(g)	(g)	(g)	(mg/L)	
1	59.98	6925.0	1523	136.31	1.13	1385.56	200.1	Y
2	60.13	6942.3	1518	139.16	0.60	1378.24	198.5	Y
3	60.08	6936.5	1520	140.16	0.34	1379.50	198.9	Y
4	59.98	6925.0	1525	137.81	0.27	1386.92	200.2	Y
5	60.02	6929.6	1521	140.72	1.92	1378.36	198.9	Y
6	60.12	6941.2	1523	140.56	1.21	1381.24	199.0	Y
7	60.06	6934.2	1518	134.16	1.56	1382.29	199.3	Y
8	59.99	6926.1	1523	139.64	0.78	1382.58	199.6	Y
9	60.11	6940.0	1522	138.06	2.08	1381.86	199.1	Y
10	60.03	6930.8	1522	137.05	7.12	1377.83	198.8	Y

*Effluent TSS*

For each run, the average effluent concentration was adjusted by subtracting the average background TSS concentration. The average adjusted effluent TSS concentration during testing was 17.82 mg/L for all the removal efficiency runs, with individual run averages ranging from 16.33 to 21.45 mg/L. Adjusted effluent TSS concentrations for each run are given in **Table 9**.

**Table 9: Removal Efficiency Testing Effluent TSS**

<b>Run #</b>	<b>Average Flow Rate</b>	<b>Effluent Water Volume</b>	<b>Average Effluent TSS</b>	<b>Average Background TSS</b>	<b>Adjusted Effluent TSS</b>	<b>Effluent Mass</b>
	(gpm)	(L)	(mg/L)	(mg/L)	(mg/L)	(g)
1	59.98	6896.6	16.90	0.50	16.40	113.10
2	60.13	6912.5	17.90	0.50	17.40	120.28
3	60.08	6907.0	17.46	1.13	16.33	112.77
4	59.98	6893.9	17.60	1.03	16.57	114.21
5	60.02	6898.3	18.32	1.47	16.85	116.26
6	60.12	6910.9	19.25	1.27	17.98	124.28
7	60.06	6901.1	18.68	1.20	17.48	120.63
8	59.99	6891.7	21.06	1.40	19.66	135.49
9	60.11	6905.3	25.12	3.67	21.45	148.14
10	60.03	6893.0	22.16	4.10	18.06	124.49

*Drawdown TSS*

According to the NJDEP Filter Protocol, the amount of sediment that leaves the filter during the drawdown period must be accounted for and documented. For each run, two evenly-volume-spaced grab samples were taken of the effluent during drawdown, and all TSS analysis was conducted by FTL. For each run, the average drawdown concentration was adjusted by subtracting the average background TSS concentration. The average adjusted drawdown TSS was 19.66 mg/L for removal efficiency runs, with individual run averages ranging from 15.67 to 23.35 mg/L. Adjusted average drawdown TSS concentrations are given in **Table 10**.

**Table 10: Removal Efficiency Testing Drawdown TSS**

<b>Run #</b>	<b>Average Flow Rate</b>	<b>Total Drawdown Volume</b>	<b>Average Drawdown TSS</b>	<b>Adjusted Drawdown TSS</b>	<b>Average Drawdown Mass</b>
	(gpm)	(L)	(mg/L)	(mg/L)	(g)
1	59.98	28.4	18.70	18.20	0.52
2	60.13	29.8	18.10	17.60	0.52
3	60.08	29.5	16.80	15.67	0.46
4	59.98	31.1	19.55	18.52	0.58
5	60.02	31.3	20.40	18.93	0.59
6	60.12	30.2	21.25	19.98	0.60
7	60.06	33.1	24.15	22.95	0.76
8	59.99	34.4	24.05	22.65	0.78
9	60.11	34.7	22.40	18.73	0.65
10	60.03	37.8	27.45	23.35	0.88

A summary of the calculations of the removal efficiencies is given in **Table 11**.

**Table 11: Summary of Removal Efficiency Results**

Run #	Net Mass Injected	Effluent Mass	Drawdown Mass	Mass Captured	Removal Efficiency	Cumulative Mass Captured	Cumulative Removal Efficiency
	(g)	(g)	(g)	(g)	(%)	(g)	(%)
1	1385.56	113.10	0.52	1271.94	91.8	1271.94	91.8
2	1378.24	120.28	0.52	1257.44	91.2	2529.38	91.5
3	1379.50	112.77	0.46	1266.27	91.8	3795.65	91.6
4	1386.92	114.21	0.58	1272.13	91.7	5067.79	91.6
5	1378.36	116.26	0.59	1261.50	91.5	6329.29	91.6
6	1381.24	124.28	0.60	1256.35	91.0	7585.64	91.5
7	1382.29	120.63	0.76	1260.89	91.2	8846.54	91.5
8	1382.58	135.49	0.78	1246.31	90.1	10092.85	91.3
9	1381.86	148.14	0.65	1233.07	89.2	11325.91	91.1
10	1377.83	124.49	0.88	1252.46	90.9	12578.38	91.1

### 5.5. Sediment Mass Capacity Testing Results

The sediment mass capacity testing was conducted as a continuation of the removal efficiency testing. In accordance with the NJDEP Protocol, all testing procedures and sampling schedules remained unchanged, except that the MTFR was reduced to 90% of the target MTFR once the maximum head was first exceeded. An additional 11 sediment mass capacity runs were completed, resulting in a total of 21 test runs.

Individual background concentrations are presented in **Table 12** for sediment mass loading capacity tests 11 through 21. All tests met the NJDEP Filtration Protocol requirements and QA/QC parameters (**Table 2, 4 and 5**). Testing was concluded after run 21 since the maximum water surface level had been reached at 90% MTFR and all applicable requirements of the protocol had been met.

The AquaLux™ achieved a cumulative removal efficiency of 90.6% for a total of 21 test runs including 10 removal efficiency runs and 11 sediment mass loading capacity runs. The sediment mass loading capacity results are summarized in **Table 15**.

### Background TSS

The background, effluent and drawdown TSS concentrations for each sediment mass capacity run are provided in **Table 12**. All background TSS concentrations were within the NJDEP maximum allowable limit of 20 mg/L. For samples with TSS reported as less than the method quantitation limit of 1.0 mg/L, a value of 0.5 mg/L was applied when calculating adjusted effluent concentrations.

**Table 12: Sediment Mass Capacity Testing Effluent, Drawdown and Background TSS**

Run #	Effluent 1 (mg/L)	Effluent 2 (mg/L)	Effluent 3 (mg/L)	Effluent 4 (mg/L)	Effluent 5 (mg/L)	Draw-down 1 (mg/L)	Draw-down 2 (mg/L)	Back-ground 1 (mg/L)	Back-ground 2 (mg/L)	Back-ground 3 (mg/L)	NJDEP Background Compliance ( $\leq 20$ mg/L)
11	19.9	19.3	20.8	21.4	21.0	25.8	24.6	2.1	2.3	2.6	Y
12	17.5	18.0	17.7	17.8	18.1	16.4	17.1	1.4	1.1	1.3	Y
13	15.7	16.7	18.1	18.9	18.6	20.1	23.1	1.2	1.5	1.2	Y
14	17.4	18.1	20.3	18.4	18.5	22.1	21.3	1.7	1.2	0.5	Y
15	18.2	21.1	21.6	21.8	15.2	20.7	17.4	1.5	3.1	3.4	Y
16	20.2	23.1	24.0	21.8	20.9	26.3	25.8	2.5	1.7	1.8	Y
17	23.7	24.9	26.5	23.9	25.1	26.7	26.2	3.6	3.5	3.0	Y
18	23.4	26.6	27.5	27.1	27.4	32.3	42.3	2.8	3.1	2.9	Y
19	26.9	26.9	28.2	24.7	26.1	29.2	31.6	2.9	2.9	1.9	Y
20	18.5	21.6	20.8	32.2	26.0	22.4	22.0	1.9	3.0	2.6	Y
21	20.3	21.4	20.8	26.6	20.6	20.6	22.0	2.2	2.5	2.3	Y

### Sediment Dosing Rate and Influent TSS

**Table 13** provides the measured sediment feed rates for each sediment mass capacity run. In this table, NJDEP Protocol compliance is defined as a COV  $\leq 0.1$ . The feed rate COV for Run 18 exceeded the 0.10 limit and is therefore disqualified from the removal efficiency evaluation; however, in accordance with NJDEP protocol, it is still included in the sediment mass capacity calculation.

**Table 13: Sediment Mass Capacity Testing Sediment Feed Rate**

Run #	Moisture Corrected Feed Rate			Average Feed Rate	Sediment Feed Rate COV	NJDEP COV Compliance ( $\leq 0.1$ )
	(g/min)			(g/min)		
11	46.484	45.793	46.659	46.312	0.010	Y
12	46.565	45.331	48.993	46.963	0.040	Y
13	46.952	45.246	46.774	46.324	0.020	Y
14	43.703	39.860	46.540	43.368	0.077	Y
15	45.214	45.896	46.902	46.004	0.018	Y
16	49.146	47.085	46.402	47.545	0.030	Y
17	47.534	47.085	46.845	47.155	0.007	Y
18	48.203	45.644	37.936	43.928	0.122	N
19	42.604	47.732	46.512	45.616	0.059	Y
20	48.355	42.275	47.454	46.028	0.071	Y
21	43.844	43.963	42.904	43.570	0.013	Y

Influent TSS concentrations as shown in **Table 14** were calculated by dividing the total mass of sediment added to the test unit (minus the mass retained in the inlet pipe) during a given run by the total volume of water flowing through the AquaLux™ test unit during the addition of test sediment during that run. The volume of water flowing through the device during the run was calculated by multiplying the average flow rate by the time of sediment injection only.

**Table 14: Sediment Mass Capacity Testing Influent TSS**

Run #	Average Flow Rate	Total Water Volume	Dosed Sediment Mass	Feed Rate Sample Mass	Sediment Recovered from Inlet	Net Mass	Influent TSS	NJDEP Compliance (180 - 220 mg/L)
	(gpm)	(L)	(g)	(g)	(g)	(g)	(mg/L)	
11	60.07	6935.4	1523.00	137.77	2.65	1382.58	199.4	Y
12	60.02	6929.6	1517.00	139.97	5.78	1371.25	197.9	Y
13	60.08	6936.5	1511.00	137.75	2.19	1371.06	197.7	Y
14	60.08	6936.5	1517.00	129.04	2.51	1385.45	199.7	Y
15	59.96	6922.7	1513.00	136.71	2.46	1373.84	198.5	Y
16	60.11	6940.0	1509.00	141.26	2.95	1364.79	196.7	Y
17	60.10	6938.8	1517.00	140.25	2.08	1374.66	198.1	Y
18	59.96	6922.7	1514.00	130.34	3.49	1380.17	199.4	Y
19	60.12	6941.2	1510.00	135.75	2.96	1371.29	197.6	Y
20	61.15	7060.1	1506.00	136.76	4.06	1365.18	193.4	Y
21	54.00	6234.6	1361.00	129.51	9.64	1221.85	196.0	Y

### *Effluent TSS*

For each sediment mass capacity run, the average effluent concentration was adjusted by subtracting the average background TSS concentration. The average adjusted effluent TSS concentration during testing was 19.56 mg/L for all the sediment mass capacity runs, with individual run averages ranging from 16.30 to 23.99 mg/L. Adjusted effluent TSS concentrations for each run are given in **Table 15**.

**Table 15: Sediment Mass Capacity Testing Effluent TSS**

<b>Run #</b>	<b>Average Flow Rate</b>	<b>Effluent Water Volume</b>	<b>Average Effluent TSS</b>	<b>Average Background TSS</b>	<b>Adjusted Effluent TSS</b>	<b>Effluent Mass</b>
	(gpm)	(L)	(mg/L)	(mg/L)	(mg/L)	(g)
11	60.07	6895.4	20.48	2.33	18.15	125.13
12	60.02	6888.5	17.82	1.27	16.55	114.03
13	60.08	6893.0	17.60	1.30	16.30	112.36
14	60.08	6892.1	18.54	1.13	17.41	119.97
15	59.96	6874.5	19.58	2.67	16.91	116.27
16	60.11	6890.7	22.00	2.00	20.00	137.81
17	60.10	6889.3	24.83	3.37	21.46	147.83
18	59.96	6872.0	26.40	2.93	23.47	161.26
19	60.12	6889.6	26.56	2.57	23.99	165.30
20	61.15	7007.4	23.82	2.50	21.32	149.40
21	54.00	6182.8	21.94	2.33	19.61	121.22

### *Drawdown TSS*

For each sediment mass capacity run, two evenly-volume-spaced grab samples were taken of the effluent during drawdown. The average drawdown concentration for each run was adjusted by subtracting the average background TSS concentration. The average adjusted drawdown TSS was 22.15 mg/L for sediment mass capacity runs, with individual run averages ranging from 15.48 to 34.37 mg/L. Adjusted average drawdown TSS concentrations are given in **Table 16**.

**Table 16: Sediment Mass Capacity Testing Drawdown TSS**

<b>Run #</b>	<b>Average Flow Rate</b>	<b>Total Drawdown Volume</b>	<b>Average Drawdown TSS</b>	<b>Adjusted Drawdown TSS</b>	<b>Average Drawdown Mass</b>
	(gpm)	(L)	(mg/L)	(mg/L)	(g)
11	60.07	40.0	25.20	22.87	0.91
12	60.02	41.1	16.75	15.48	0.64
13	60.08	43.6	21.60	20.30	0.88
14	60.08	44.4	21.70	20.57	0.91
15	59.96	48.2	19.05	16.38	0.79
16	60.11	49.3	26.05	24.05	1.19
17	60.10	49.6	26.45	23.08	1.14
18	59.96	50.7	37.30	34.37	1.74
19	60.12	51.6	30.40	27.83	1.43
20	61.15	52.7	22.20	19.70	1.04
21	54.00	51.8	21.30	18.97	0.98

A summary of the calculations of the removal efficiencies is given in **Table 17**.

**Table 17: Summary of Sediment Mass Capacity Results**

<b>Run #</b>	<b>Net Mass Injected</b>	<b>Effluent Mass</b>	<b>Drawdown Mass</b>	<b>Mass Captured</b>	<b>Removal Efficiency</b>	<b>Cumulative Mass Captured</b>	<b>Cumulative Removal Efficiency</b>
	(g)	(g)	(g)	(g)	(%)	(g)	(%)
11	1382.58	125.13	0.91	1256.54	90.9	13834.92	91.0
12	1371.25	114.03	0.64	1256.59	91.6	15091.51	91.1
13	1371.06	112.36	0.88	1257.82	91.7	16349.33	91.1
14	1385.45	119.97	0.91	1264.57	91.3	17613.90	91.1
15	1373.84	116.27	0.79	1256.78	91.5	18870.67	91.2
16	1364.79	137.81	1.19	1225.79	89.8	20096.47	91.1
17	1374.66	147.83	1.14	1225.69	89.2	21322.15	91.0
18	1380.17	161.26	1.74	1217.34	--	22539.49	--
19	1371.29	165.30	1.43	1204.55	87.8	23744.04	90.7
20	1365.18	149.40	1.04	1214.74	89.0	24958.78	90.6
21	1221.85	121.22	0.98	1099.65	90.0	26058.43	90.6

## 5.6. Sediment Mass Loading

Sediment mass loading was calculated from the summation of the total sediment mass added during dosing in each run. Overall, a total of 28.78 kg (63.4 lbs) of sediment was loaded into the ALUX-3M over the course of the 21 runs. Total captured mass over the 21 runs was 26.06 kg (57.4 lbs).

The relationship between removal efficiency and cumulative sediment mass loading is shown in **Figure 6**.

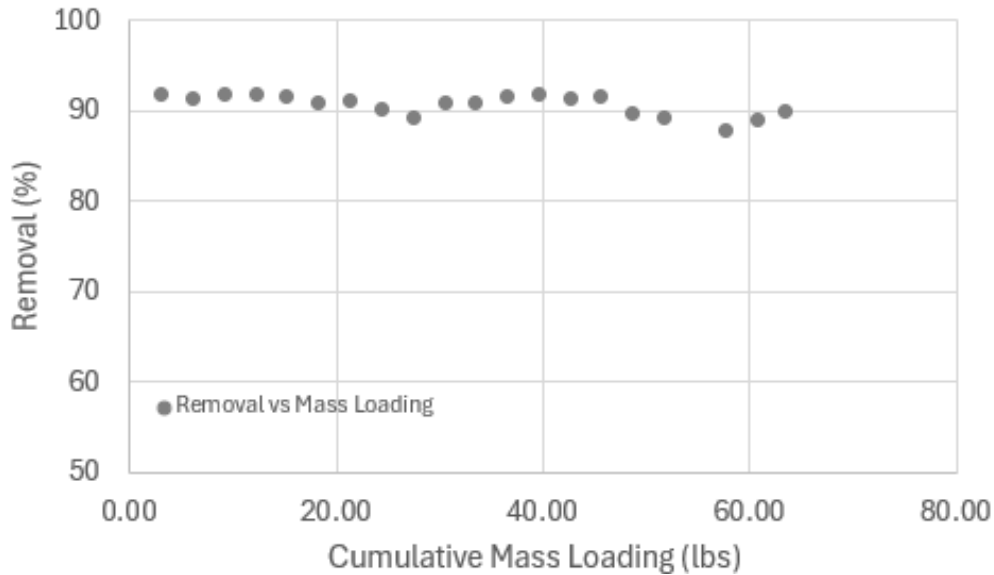

**Figure 6: Removal Efficiency vs. Sediment Mass Loading**

The relationship between head and cumulative sediment mass loading is shown in **Figure 7**.

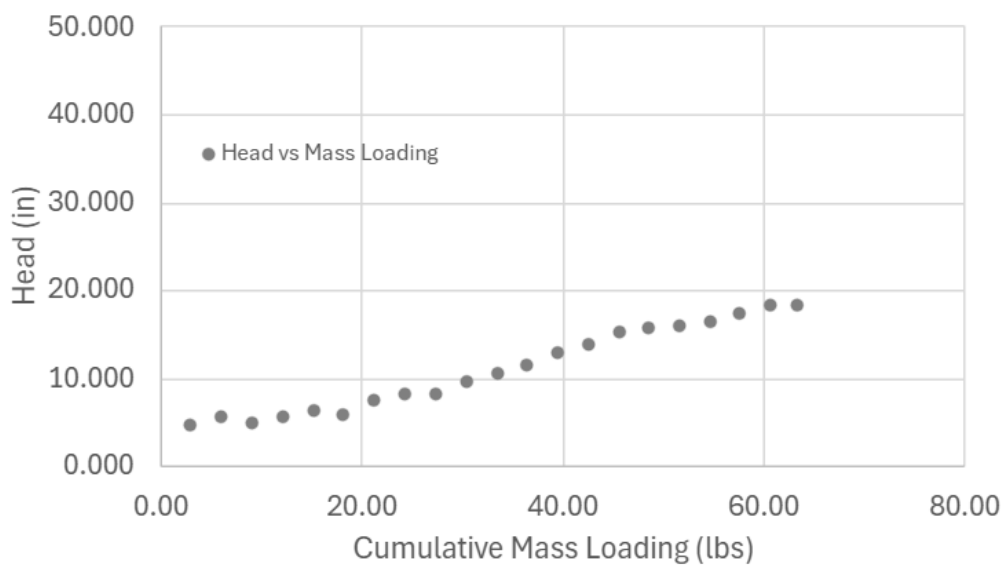

**Figure 7: Head vs. Sediment Mass Loading**

## 5.7. Scour Test Results

The scour test took place on ALUX-3M that had been pre-loaded per the procedure in the NJDEP filter Protocol (Updated April 25, 2023) with >50% of the manufacturer’s recommended maximum sediment storage volume. The flow rate during the scour run averaged 125 gpm (208% of MTRF), with a COV of 0.0095, which is in compliance with the NJDEP Filter Protocol. The maximum water temperature during the scour run was 63.1 degrees Fahrenheit, which is also in compliance with the NJDEP Filter Protocol.

Scour testing began by increasing the flow rate to the target flow within a three-minute period. Effluent and background samples were taken from the same locations as for the removal efficiency test and sediment mass capacity test. Fifteen effluent samples were taken at times of 1, 3 and 5 minutes after the commencement of conveying clear water through the test unit, and then every two minutes thereafter for an additional 12 samples (i.e., 7, 9, 11...29 minutes) as shown in the scour sampling schedule in **Table 18**.

**Table 18: Scour Test Sampling Schedule**

Sample	Run Time (minute)															
	0	1	3	5	7	9	11	13	15	17	19	21	23	25	27	29
Effluent		X	X	X	X	X	X	X	X	X	X	X	X	X	X	X
Background		X		X		X		X		X		X		X		X

Scour test TSS results are presented in **Table 19**. The maximum background TSS concentration was 1.8 mg/L, which is below the maximum of 20 mg/L allowed by the NJDEP Filter Protocol. Each effluent TSS concentration was adjusted by subtracting the background concentration. For samples that did not have a corresponding background sample, the background TSS concentration was interpolated from the previous and subsequent background samples TSS concentrations. The average adjusted TSS concentration of the effluent was 9.12 mg/L. As this value is below the NJDEP-Protocol-specified limit of 20 mg/L, the AquaLux™ Filtration system met the requirement for on-line use.

**Table 19: Scour Test TSS Results**

Sample #	Scour Test TSS Concentrations (mg/L)														
	1	3	5	7	9	11	13	15	17	19	21	23	25	27	29
Effluent	53.9	36.6	13.1	10.6	7.6	3.9	5.2	4.2	8	2.9	3.4	2.5	2.9	2.3	2.5
Background	1.5		1.4		1.4		1.6		1.7		1.4		1.4		1.8
Adjusted Effluent	52.4	35.2	11.7	9.2	6.2	2.4	3.6	2.6	6.3	1.4	2.0	1.1	1.5	0.7	0.7
Average adjusted Effluent Concentration (mg/L)								9.1							

## 6. Design Limitations

### *Maximum Flow Rate*

The ALUX-3M has an MTFR of 0.134 cfs (60 gpm) and an effective filtration treatment area (EFTA) of 411 ft<sup>2</sup> (loading rate = 0.146gpm/ft<sup>2</sup>).

### *Slope*

The AquaLux™ system is recommended for installation with little to no slope to ensure proper, consistent operation. Steep slopes should be reviewed by ADS Engineering support.

### *Allowable Head Loss*

There is an operational head loss associated with the AquaLux™. The head loss will increase over time due to sediment loading to the system. AquaLux™ is configured with an internal bypass, a design head loss of 18 inches (from invert of the outlet pipe). Site-specific treatment flow rates, peak flow rates, pipe diameter, and pipe slopes should be evaluated to ensure there is an appropriate head for the system to function properly.

### *Sediment Load Capacity*

Based on laboratory results, the ALUX-3M has a mass loading capacity of 63.4 lbs while operating at a cumulative sediment removal efficiency of 91.1 %.

### *Pre-treatment Requirements*

The AquaLux™ does not require pre-treatment.

### *Configurations*

The AquaLux™ system is available in multiple configurations, including both manhole and vault structures, and can be equipped with either pipe inlets or curb inlets. The unit may be installed in either an online or offline configuration. The standard AquaLux™ model includes an internal bypass, while other configurations may rely on an upstream external bypass that serves as the primary conveyance path for higher flows.

### *Structural Load Limitations*

Most standard structures are designed to handle H-20 traffic loads. For deeper installations or installations requiring a greater load capacity, the system will be designed and manufactured to meet those requirements. ADS provides full-service technical design support throughout the life of a project and can help ensure the system is designed for the appropriate structural load requirements.

## 7. Maintenance

### *General Inspection*

The AquaLux™ system requires periodic inspection and maintenance to ensure operation at design efficiency. Inspections help determine when maintenance is required and the level of service necessary to restore the unit to peak performance. As with other ADS water quality products, the maintenance frequency for AquaLux™ is primarily driven by the actual sediment load entering the system. Therefore, maintenance intervals are site-specific and depend on pollutant loading conditions.

During the first year of operation, inspections should be conducted quarterly, with additional inspections performed after major storm events occurring within the first six months (defined as storms producing rainfall intensity  $\geq 1$  inch/hour intensity or  $\geq 3$  inches within 24 hours). After the first year, inspections should occur at least twice annually - ideally once before the spring/rainy season and once after the summer season or prior to fall/winter. Additional inspections may be warranted following periods of excessive sediment loading caused by site erosion or non-stormwater runoff events such as seasonal baseflow.

All inspections are performed from the surface and do not require confined-space entry. Key items to evaluate include the presence of standing water in the inlet chamber, sediment accumulation depth in the sump, trash and debris buildup, signs of erosion, and any physical damage to the deck or filter caps. An Operation and Maintenance (O&M) log should be maintained to document inspection dates and weather conditions. A follow-up inspection should be completed within 24 hours after a major storm event to determine whether water remains ponded within the inlet chamber; persistent ponding may indicate the need filter replacement.

### *Inspection and General Maintenance Equipment*

Recommended equipment includes:

- Personal Protective Equipment (steel-toed boots, gloves, safety glasses, safety vest, hard hat, etc.)
- Manhole hook or crowbar
- Traffic cones and signage
- Stadia rod and tape measure
- Inspection O&M Guide
- Vacuum truck (for sediment removal)
- Light-duty construction equipment (if required)

## *General Inspection and Maintenance Procedures*

Routine maintenance generally involves removing accumulated water, oil, sediment, and debris from the system. This is typically performed using a vacuum truck capable of extracting both liquids and solids from the treatment chamber. Once the chamber has been emptied, the interior surfaces of the vault or manhole should be cleaned using high-pressure washing equipment to remove residual material and restore proper hydraulic function.

Filter cartridges should be removed, rinsed thoroughly, and reinstalled once cleaned. If any filter elements show signs of wear, clogging, or structural degradation, they should be replaced to ensure continued treatment performance. Sediment that has accumulated in the sump should also be removed during each maintenance event to prevent resuspension and to maintain available storage capacity.

All materials removed during maintenance - including liquids, solids, and filter residues - must be disposed of at an approved facility in accordance with local and regional regulations. Most jurisdictions prohibit the discharge of solid materials into the sanitary sewer system, and liquid discharge may require prior authorization. In some areas, the collected material may be classified as leachate or a regulated waste stream; therefore, it is important to consult local authorities to confirm proper handling and disposal requirements.

Disposal of material from the treatment chamber should be in accordance with the local municipality's requirements. Typically, traditional municipal landfills can be used for disposal of solids and trash obtained from servicing the AquaLux™ system. Call ADS at 800-821-6710 for further information. See the O&M Guidance Manual at:

<https://assets.adspipe.com/asset/c364ffa8-75ac-4e33-9757-89b7d31efd5f/AquaLuxTM-Maintenance-Guide.pdf>

## **8. Statements**

The attached include signed statements from the manufacturer (Advanced Drainage Systems, Inc.), the independent third-party observer (Sustainable Stormwater Solutions Engineering, Dr. Ryan Winston), and NJCAT. These statements are included as requirement for the verification process.



*Sustainable Stormwater Solutions Engineering*

May 12, 2026

To: Gordon Baugh, Advanced Drainage Systems, Inc. (ADS)  
From: Ryan Winston, PhD, P.E., BC.WRE, Sustainable Stormwater Solutions Engineering, LLC  
Subject: Third Party Verification of AquaLux™ Filtration System  
CC: Bo Liu, Advanced Drainage Systems, Inc. (ADS)

Subject: **Witness Statement**  
**Third Party Observer**

Sustainable Stormwater Solutions Engineering (SSSE) served as the third-party observer for sediment removal efficiency, mass capacity, and scour testing performed on the AquaLux™ Stormwater Filtration Treatment System ALUX-3M. This testing was performed in the Hydraulics Laboratory of ADS, Inc., located in their Engineering and Technology Center at 4671 Raindrop Way, Hilliard, Ohio. Hydraulics, removal efficiency, and scour tests were performed in April 2026 following QAPP approval in March 2026. Tests were conducted to confirm performance of ALUX-3M through the New Jersey Department of Environmental Protection (NJDEP) according to the *Laboratory Protocol to Assess Total Suspended Solids Removal by a Filtration Manufactured Treatment Device* (NJDEP protocol). This document was dated January 14, 2022, and subsequently updated on April 25, 2023. I was on site during all tests documented in the attached report and verified the compliance with the test protocol above. I was present to observe all testing procedures including sampling intervals, sample volumes, flow rates, water temperature measurements, head loss calculations, sediment feed rate, sediment recovery, and sediment mass captured in the inlet pipes and test unit. I was present and witnessed labeling, completion of Chain of Custody forms, and packaging of samples for shipment to the external laboratory.

I have reviewed the data, calculations, and conclusions associated with the hydraulic, removal efficiency, and scour testing in the AquaLux Stormwater Filtration Treatment System ALUX-3M report by ADS, Inc. dated May 2026. I state that the results presented therein conform to what I observed during my supervision as a third-party observer.

Thank you,



Ryan J. Winston, PhD, P.E., BC.WRE  
Sustainable Stormwater Solutions Engineering



*Sustainable Stormwater Solutions Engineering*

May 12, 2026

To: Gordon Baugh, Advanced Drainage Systems, Inc. (ADS)  
From: Ryan Winston, PhD, P.E., BC.WRE, Sustainable Stormwater Solutions Engineering, LLC  
Subject: Third Party Verification of AquaLux™ Stormwater Filtration Treatment System  
CC: Bo Liu, Advanced Drainage Systems, Inc. (ADS)

Subject: **Conflict of Interest Statement**

Sustainable Stormwater Solutions Engineering, LLC (SSSE) served as the third-party observer for removal efficiency, mass capacity, and scour tests performed on the AquaLux™ Stormwater Filtration Treatment System ALUX-3M in April 2026. Tests were conducted to achieve certification through the New Jersey Department of Environmental Protection (NJDEP) according to the *Laboratory Protocol to Assess Total Suspended Solids Removal by a Filtration Manufactured Treatment Device* (NJDEP protocol). SSSE has no financial conflict of interest regarding the test results of this stormwater treatment device. SSSE and ADS have no relationships beyond this testing agreement that would constitute a conflict of interest. For instance, SSSE does not own stock in ADS, have partial ownership of the company, and have licensing agreements with the company. We have not received funds from ADS beyond those associated for third party observation of testing for the AquaLux™.

Thank you,



Ryan J. Winston, PhD, P.E., BC.WRE  
Sustainable Stormwater Solutions Engineering



**Rutgers EcoComplex  
1200 Florence Columbus RD  
Bordentown, NJ 08505-4200**

May 24, 2026

Gabriel Mahon, Chief  
NJDEP  
Bureau of Non-Point Pollution Control  
Division of Water Quality  
401 E. State Street  
Mail Code 401-02B, PO Box 420  
Trenton, NJ 08625-0420

Dear Mr. Mahon,

Based on my review, evaluation and assessment of the testing conducted on a commercially available ADS AquaLux™ Filtration System during the spring of 2026 the test protocol requirements contained in the “*New Jersey Department of Environmental Protection Laboratory Protocol to Assess Total Suspended Solids Removal by a Filtration Manufactured Treatment Device*” (NJDEP Filtration Protocol dated January 14, 2022 (updated April 25, 2023) were met or exceeded. All removal efficiency, sediment mass loading capacity, and scour testing for this project were carried out at the ADS Engineering and Technology Center’s Hydraulics Laboratory in Hilliard, Ohio. Independent third-party observation for all testing was provided by NJCAT approved Sustainable Stormwater Solutions Engineering (SSSE). SSSE provided third-party review and oversight of all testing and data collection. Specifically:

*Test Sediment Feed*

Test sediment used for removal efficiency and sediment mass loading capacity testing was a silica blended mixture compliant with the NJDEP PSD requirements and provided by AGSCO corporation. Test sediment PSD samples were collected under third-party observation following ASTM E3317(2022) Standard Specification for Silica-Based Sediment for the Evaluation of Stormwater Treatment Devices. PSD sediment samples were analyzed by Bowser-Morner, Inc. (BMI) an ISO certified independent, accredited analytical laboratory, for processing according to ASTM D6913(2017) Standard Test Methods for Particle-Size Distribution (Gradation) of Soils Using Sieve Analysis, ASTM D7928(2021) Standard Test Method for Particle Size Distribution (Gradation) of Fine-Grained Soils Using the Sedimentation (Hydrometer) Analysis, and ASTM D2216 (2019) Standard Test Methods for Laboratory Determination of Water (Moisture) Content of Soil and Rock by Mass. Sediment containers were affixed with quality seals under third-party observation and

remained sealed until opened and utilized for testing under 3<sup>rd</sup> party observation. The measured and interpolated result indicates compliance with the requirements of the NJDEP Protocol. The test sediment distribution was finer than the specification, with a  $d_{50}$  particle size of 67.5  $\mu\text{m}$ . The moisture content was 0.0%.

#### *Removal Efficiency (RE) Testing*

A total of 10 removal efficiency tests and 11 additional sediment mass loading capacity tests were performed in accordance with the NJDEP Filtration Protocol. The target influent concentration and MTFR were 200 mg/L and 60 gpm, respectively. All tests met the NJDEP Protocol requirements and QA/QC parameters. All sediment concentration samples collected during the test program were analyzed by an independent, accredited environmental testing laboratory, Fredericktowne Labs (FTL) using ASTM D3977 “Standard Test Methods for Determining Sediment Concentration in Water Samples.” The AquaLux achieved a cumulative removal efficiency of 91.1% for tests 1 through 10.

#### *Sediment Mass Loading Capacity*

The sediment mass loading capacity testing was a continuation of the removal efficiency study. An additional 11 sediment mass loading capacity tests were completed, resulting in a total of 21 tests. As required by the NJDEP protocol, all aspects of testing remained the same, except that the MTFR was reduced to 90% of the target after the maximum head (18-in) was initially exceeded. The sediment mass loading capacity sampling schedule remained the same. The AquaLux achieved a cumulative removal efficiency of 90.6% for the 21 tests.

The total influent mass loaded through Run 21 was 63.4 lbs and the total mass captured by the AquaLux Filtration System was 57.4. This is equivalent to a sediment mass loading capacity of 0.14 lbs/ft<sup>2</sup> of EFTA.

No maintenance was performed on the test system during the testing program.

#### *Scour Testing*

The scour test flow rate averaged 125.0 gpm (208% of the MTFR) with a COV of 0.0095. The maximum water temperature during the scour test was 63.1 °F. No background concentration exceeded 20 mg/L during scour testing. The average adjusted effluent TSS concentration was 9.1 mg/L.

Sincerely,



Richard S. Magee, Sc.D., P.E., BCEE  
Executive Director

## 9. References

ADS (2026). *QAPP for Verification Testing of the Advanced Drainage Systems Stormwater Filtration Treatment System AquaLux™ in accordance with the NJDEP Testing Protocol.*

ASTM D6913-17 (2018). *Standard Test Methods for Particle-Size Distribution (Gradation) of Soils Using Sieve Analysis.*

ASTM D7928-17 (2021). *Standard Test Method for Particle-Size Distribution (Gradation) of Fine-Grained Soils Using the Sedimentation (Hydrometer) Analysis.*

ASTM D3977-97 (2019). *Standard Test Methods for Determining Concentrations in Water Samples.*

NJDEP 2023. *New Jersey Department of Environmental Protection Laboratory Protocol to Assess Total Suspended Solids Removal by a Filtration Manufactured Treatment Device.* Trenton, NJ. April 25, 2023

## **VERIFICATION APPENDIX**

### ***Introduction***

- Manufacturer –Advanced Drainage Systems, Inc., 4024 Green Stripe Lane, Hilliard, OH 43206. Website: [adspipe.com](http://adspipe.com) Phone: 800-733-7473.
- AquaLux™ verified models are shown in **Table A-1**.
- TSS Removal Rate – 80%
- On-line installation

### ***Detailed Specification***

- NJDEP sizing tables and physical dimensions of the AquaLux™ verified models are attached (**Table A-1**).
- Pick weights and installation procedures vary slightly with model size. Design support is given by the ADS Water Quality Team for each project and pick weights and installation procedures will be provided prior to delivery.
- Maintenance Guide is at:  
<https://assets.adspipe.com/asset/c364ffa8-75ac-4e33-9757-89b7d31efd5f/AquaLuxTM-Maintenance-Guide.pdf>
- Under N.J.A.C. 7:8-5.5, NJDEP stormwater design requirements do not allow a filtration device such as the AquaLux™ filtration system to be used in series with another filtration device to achieve an enhanced TSS removal rate.

**Table A-1 AquaLux Model MTFRs and New Jersey Maximum Allowable Drainage Area**

<b>Model</b>	<b>ESTA (ft<sup>2</sup>)</b>	<b>(EFTA) (ft<sup>2</sup>)</b>	<b>WV (ft<sup>3</sup>)</b>	<b>MTFR<sup>1</sup> (cfs)</b>	<b>ESTA/ EFTA</b>	<b>WV/ EFTA</b>	<b>Surface Loading Rate (gpm/ft<sup>2</sup>)</b>	<b>Mass Capture Capacity (lbs)</b>	<b>Maximum Allowable Drainage Area<sup>2</sup> (acres)</b>
ALUX-3M	3.01	411	14.81	0.134	0.0073	0.036	0.146	57.4	0.096
ALUX-7M	7.07	959	34.75	0.312	0.0074	0.036	0.146	133.9	0.223
ALUX-12M	12.57	1644	61.78	0.535	0.0076	0.038	0.146	229.6	0.383
ALUX-19M	19.63	2603	96.54	0.847	0.0075	0.037	0.146	363.6	0.606
ALUX-27M	28.27	3699	139.02	1.203	0.0076	0.038	0.146	516.7	0.861
ALUX-48M	50.27	6576	247.14	2.139	0.0076	0.038	0.146	918.5	1.531
ALUX-75M	78.54	10275	386.15	3.342	0.0076	0.038	0.146	1435.1	2.392
ALUX-10	14	1370	68.8	0.446	0.0102	0.050	0.146	191.4	0.319
ALUX-20	22	2740	108.2	0.891	0.0080	0.039	0.146	382.7	0.638
ALUX-30	30	4110	147.5	1.337	0.0073	0.036	0.146	574.1	0.957
ALUX-35	38	4795	186.8	1.560	0.0079	0.039	0.146	669.7	1.116
ALUX-28	33	3836	162.3	1.248	0.0086	0.042	0.146	535.8	0.893
ALUX-42	45	5754	221.3	1.872	0.0078	0.038	0.146	803.7	1.339
ALUX-49	51	6713	250.8	2.184	0.0076	0.037	0.146	937.6	1.563
ALUX-56	57	7672	280.3	2.496	0.0074	0.037	0.146	1071.6	1.786
ALUX-40	44	5480	216.3	1.783	0.0080	0.039	0.146	765.4	1.276
ALUX-60	60	8220	295.0	2.674	0.0073	0.036	0.146	1148.1	1.914
ALUX-70	76	9590	373.7	3.120	0.0079	0.039	0.146	1339.5	2.232
ALUX-90	92	12330	452.3	4.011	0.0075	0.037	0.146	1722.2	2.870
ALUX-100	108	13700	531.0	4.456	0.0079	0.039	0.146	1913.5	3.189
ALUX-120	124	16440	609.7	5.348	0.0075	0.037	0.146	2296.2	3.827
ALUX-150	156	20550	767.0	6.685	0.0076	0.037	0.146	2870.3	4.784

**Table A-1 AquaLux Model MTFRs and New Jersey Maximum Allowable Drainage Area**

<b>Model</b>	<b>ESTA (ft<sup>2</sup>)</b>	<b>(EFTA) (ft<sup>2</sup>)</b>	<b>WV (ft<sup>3</sup>)</b>	<b>MTFR<sup>1</sup> (cfs)</b>	<b>ESTA/ EFTA</b>	<b>WV/ EFTA</b>	<b>Surface Loading Rate (gpm/ft<sup>2</sup>)</b>	<b>Mass Capture Capacity (lbs)</b>	<b>Maximum Allowable Drainage Area<sup>2</sup> (acres)</b>
ALUX-108	115	14796	565.4	4.813	0.0078	0.038	0.146	2066.6	3.444
ALUX-132	135	18084	663.8	5.883	0.0075	0.037	0.146	2525.9	4.210
ALUX-168	175	23016	860.4	7.487	0.0076	0.037	0.146	3214.7	5.358
ALUX-192	195	26304	958.8	8.556	0.0074	0.036	0.146	3674.0	6.123
ALUX-126	138	17262	678.5	5.615	0.0080	0.039	0.146	2411.0	4.018
ALUX-154	162	21098	796.5	6.863	0.0077	0.038	0.146	2946.8	4.911
ALUX-182	186	24934	914.5	8.111	0.0075	0.037	0.146	3482.6	5.804
ALUX-210	210	28770	1032.5	9.359	0.0073	0.036	0.146	4018.4	6.697
ALUX-224	234	30688	1150.5	9.983	0.0076	0.037	0.146	4286.3	7.144

1. MTFR is based on 0.146 gpm/ft<sup>2</sup> (0.0003253 cfs/ft<sup>2</sup>) of effective filtration treatment area.
2. Drainage area is calculated based on 600 lbs. of mass contributed per acre of drainage area annually.